

| Technical Specifications | |
|------------------------------------------------------------------|-------------------------|
| Usage: | |
| Use with the following: | |
| GOALZERO Sherpa 50 recharger v2 GOALZERO Sherpa 100 recharger | |
| Inputs | |
| 12V Port (9mm) | 9-13V, 0-10A (100W max) |
| Outputs | |
| AC Outlet (Euro) | 220VAC (100W max) |
| Sherpa 50: | 65W |
| Sherpa 100: | 100W |
| | |
| | |
| | |
| | |

| General | |
|----------------------|--------------------------------------------|
| Weight | 0.35 lbs (0.16 kg) |
| Dimensions | 1 x 1.5 x 5.25 in (2.54 x 2.54 x 13.34 cm) |
| Warranty | 12 months |
| Certifications | FCC,CE |
| Operating usage temp | 32-104F (0-40C) |

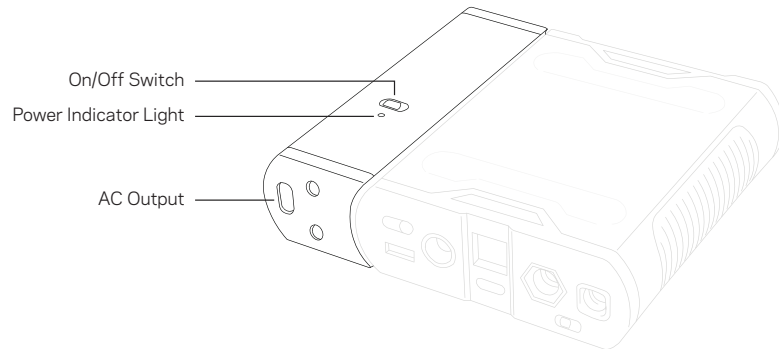

Know Your Gear

SHERPA

A C I N V E R T E R

User Guide



- Register your product
- Watch demo video
- Download user manual

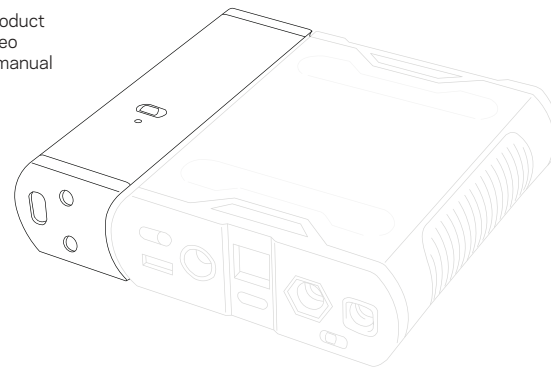

Contact Us:
Toll Free: 888-794-6250
675 West 14600 South
Bluffdale, UT 84065
www.GOALZERO.com

We proudly support Tifie Humanitarian
www.tifie.org

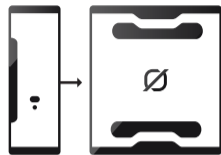

ATTACH

Bolt to side-car port of the SHERPA recharger. Turn ON both the INVERTER and the SHERPA.

1

POWER

Plug in any AC* device.



2

*Up to 100 Watts

CONSERVE



Switch INVERTER to OFF when not in use.

3

Frequently Asked Questions

Q: Is the Sherpa Inverter waterproof?
A: No. Do not use the Sherpa Inverter if it is wet. If it gets wet, allow it to dry completely before using it.

Q: Can I use the Sherpa Inverter with chained Goal Zero Sherpa Rechargers?
A: Yes, but make sure to attach Sherpa Inverter and chaining cord, and turn on all Sherpa Rechargers.

Q: Can I use the Sherpa Inverter as a stand-alone source of power?
A: No. The Sherpa Inverter is specifically designed to enhance the capabilities of the Sherpa Recharger. It is NOT a battery, and cannot power items on its own.

Q: Do I have to have a Sherpa Recharger to use my inverter?

A: The Sherpa Inverter can be used with Sherpa Rechargers, as well as in your car with the Sherpa Inverter Car Adapter (sold separately).

Visit goalzero.com for more information.