

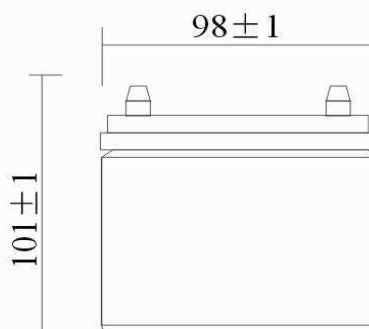

ST 120

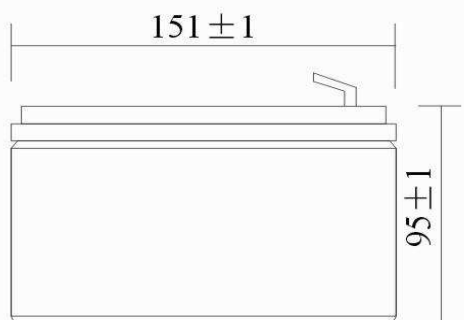

**CARACTERISTIQUES MECANIQUES
PHYSICAL SPECIFICATIONS**

TENSION NOMINALE / <i>NOMINAL VOLTAGE</i>		12 V
CAPACITE / <i>NOMINAL CAPACITY (20HR)</i>		13.2 Ah
DIMENSIONS	Longueur / <i>Length</i>	151 mm
	Largeur / <i>Width</i>	98 mm
	Hauteur / <i>Total Height (with terminal)</i>	95 mm
MASSE / <i>WEIGHT</i>		4.3 Kg
TYPE DE BORNE / <i>STANDARD TERMINAL</i>		FASTON 6,35 mn - Type 250

**CARACTERISTIQUES ELECTRIQUES
ELECTRICAL SPECIFICATIONS**

CAPACITE / <i>RATED CAPACITY</i> 1,8 V/élément - 1,8 V/cell	20 hour rate	13.2 AH
	10 hour rate	12.6 AH
	5 hour rate	11.05 AH
	3 hour rate	9.96 AH
	1 hour rate	7.09 AH
INFLUENCE DE LA TEMPERATURE SUR LA CAPACITE / <i>CAPACITY</i> AFFECTED BY TEMPERATURE	40°C (104°F)	103%
	25°C (77°F)	100%
	0°C (32°F)	86%
RESISTANCE INTERNE / <i>INTERNAL RESISTANCE</i>	Fully charged battery 14 milliohms (25°C, 77°F)	
COURANT MAXI EN 10 sec. / <i>CURRENT MAXI 10S</i>		0.198 KA (end of voltage 1,6V/cell)
COURANT MAXI EN 5 sec. / <i>CURRENT MAXI 5S</i>		0.264 KA (end of voltage 1,6V/cell)
COURANT DE COURT-CIRCUIT / <i>SHORT-CIRCUIT CURRENT</i>		0.660KA