

VENTURE[®] 75

POWER BANK

USER GUIDE





PLUG ME IN

Venture 75 is in protective shipping mode.
Plug it into a USB port before using.

BRANCHEZ-MOI: Votre Venture 75 est en mode de transport. Branchez-le sur un port USB avant de l'utiliser.

これを差し込んで下さい。Venture 75は保護モードで出荷されています。ご使用前にUSBポートに差し込んで下さい。

STECK MICH ZUERST EIN: Das Venture 75 wird im Schutzmodus geliefert. Vor dem ersten Gebrauch in einen USB-Port einstecken.

CONÉCTEME: El Venture 75 está en modo protector de envío. Conéctelo a un puerto USB antes de usarlo.

Table of Contents

Get To Know Your Gear	2
Charge Before Use	3
Solar Ready™	3
Charge Your Gear	4
Flashlight	4
Rugged Design	4
Frequently Asked Questions	5
Technical Specifications	6
Français	8
Deutsch	14
Español	20
Italiano	26
Portugués	32
日本語	38
Suomalainen	44
Nederlands	50
Svenska	56

GET TO KNOW YOUR GEAR

Fast-charging technology meets rugged durability. The new Venture 75 blends the best of both worlds. Our upgraded 19200 mAh power bank features an IP67 dustproof/waterproof rating and a USB-C port designed to speed up charging and streamline cable carrying. Power up tablets, laptops, and other USB-C devices using the 60W USB-C Power Delivery port, then use the same port to quickly recharge the power bank in 1.5 hours. The fresh Venture design features a protective rubber sleeve, integrated 50 lumen flashlight, and a waterproof plug that protects your ports against the elements when not in use.

Battery Indicator Lights

- 1: 25% charge
- 2: 50% charge
- 3: 75% charge
- 4: 100% charge

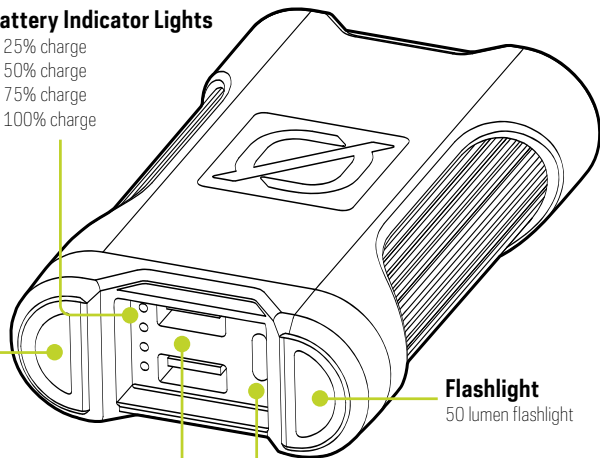

Flashlight
50 lumen flashlight

2x USB-A Output Ports
5V, up to 3A each (15W max), regulated

USB-C Input/Output Port
5-20V, up to 3A (60W max), regulated

Flashlight On/Off | Indicator
Flashlight & battery level indicator

CHARGE BEFORE USE ⚠

Use the included USB-C cable to charge up the Venture 75 from a live USB source. Use the 45W USB-C charger (sold separately) for a high-speed input. A new Venture 75 comes in a protective mode to prevent self-discharge, potentially caused by long periods of inactivity, like shipping.

The Venture 75 will not charge your gear until it is plugged into a live USB source.

1. Connect the USB-C cable into the input and plug it into a live USB port.
2. You will know it's charging when blue indicator lights on the front illuminate and Flash. Each blue indicator light represents 25% battery capacity. As the battery fills the charge state will flash blue.
3. The Venture 75 is full and ready to go when all lights are solid.
4. The Venture 75 allows for simultaneous discharging and recharging so you can charge your gear and Venture 75 at the same time.

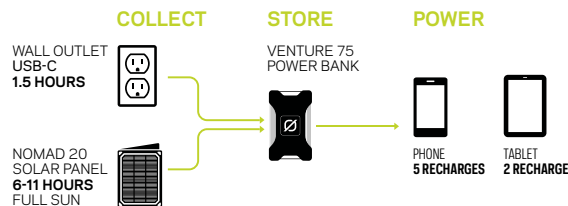

SOLAR READY™

Venture 75 is engineered to charge quickly from Goal Zero Nomad® Solar Panels.

1. Connect the USB-C end of the included cable into the Venture 75 and plug the USB-A end into the USB port on the back of the Nomad panel.
2. You will know it's charging when blue indicator lights illuminate and flash. Each blue indicator light represents 25% battery capacity.
3. The Venture 75 is full and ready to go when all lights are solid together.
4. Blue indicator lights will flash according to the battery level. When charging from solar, use the built-in kickstand to angle your panel toward the sun.



NOMAD 10
11-22 HOURS



NOMAD 20
6-11 HOURS



NOMAD 50
6 HOURS

CHARGE YOUR GEAR

The Venture 75 is designed to charge phones, tablets, POV cameras, and other USB powered devices. Charge up to 3 devices simultaneously.



HEADLAMP
UP TO 14
RECHARGES



POV CAMERA
14
RECHARGES



PHONE
5
RECHARGES



TABLET
2
RECHARGES



LAPTOP
UP TO 1
RECHARGE

FLASHLIGHT

The Venture 75 comes with a built in 50 lumen flashlight.

TURN ON/OFF

Press the Power Batt/Flashlight button for 2 seconds to turn on and off.

RUGGED DESIGN

The Venture 75's IP67 rating lets you power through any adventure, rain or shine. When waterproof port plug is fully closed, the Venture 75 is protected against dust, sand, and debris, and can withstand submersion up to 1 meter of water for at least 30 minutes.

FREQUENTLY ASKED QUESTIONS

Q: Why is my gear not charging?

A: Check the battery level of the Venture 75 by pressing the power battery indicator button. Make sure to use the certified cables that came with your gear.

Q: Is the Venture 75 fully waterproof?

A: Yes with the waterproof door fully closed, the unit is rated at IP67 and is protected against dust, sand, and debris, and can withstand submersion up to 1 meter of water for at least 30 minutes.

Q: How does the flashlight function?

A: The Venture 75 has a built in 50 lumen flashlight controlled by the battery indicator power button. Simply press the button down for 2 seconds to turn the flashlight on and off.

Q: What if the power from my USB-C devices is not flowing the correct way?

A: The USB-C port on the Venture 75 is bi-directional. Meaning power can flow in and out. If the power is not flowing the way you would like, try to unplug and re-plug the USB-C cable once or twice. This will re-register the direction the power is flowing.

TECHNICAL SPECIFICATIONS

Venture 75 Power Bank

CHARGE TIMES:

GOAL ZERO Nomad 10	11-22 hrs
GOAL ZERO Nomad 20	6-11 hrs
GOAL ZERO Nomad 50	6 hrs
USB-C Source (60W)	1.5 hrs



BATTERY:

Cell chemistry	Li-ion NMC
Cell type	18650 by LG chem
Cell capacity	71.04Wh (11.1V, 6400mAh)
Single Cell capacity	19200mAh @ 3.7V
Lifecycles	Hundreds of cycles
Shelf-life	Keep plugged in, or charge every 3-6 months
Fuses	None
Management system	Charging and low-battery protection built-in

PORTS:

USB port (output)	5V, up to 3A each (1.5W max), regulated
USB-C port (input/output)	5-20V, up to 3A (60W max), regulated

GENERAL:

IP Rating	IP67
Chainable	No
Weight	1.27 lbs (577 g)
Dimensions	6.1 x 3.8 x 1.1 in (15.6 x 9.6 x 2.9 cm)
Operating usage temperature	32-113F (0-45C)
Certifications	  
Warranty	12 months

Be sure to **ACTIVATE YOUR WARRANTY**
at goalzero.com/warranty

POWER. ANYTHING. ANYWHERE.™



La technologie de charge rapide rencontre une durabilité robuste. Le nouveau Venture 75 allie le meilleur des deux mondes. Notre batterie externe améliorée de 19200 mAh est dotée d'un indice d'étanchéité à la poussière/étanche IP67 et d'un port USB-C conçu pour accélérer la charge et rationaliser le transport des câbles. Alimentez vos tablettes, ordinateurs portables et autres périphériques USB-C à l'aide du port d'alimentation USB-C de 60 W, puis utilisez le même port pour recharger rapidement le bloc d'alimentation en 1,5 heure. Le nouveau design du Venture comprend un manchon de protection en caoutchouc, une lampe de poche intégrée de 50 lumens et une prise étanche qui protège vos ports contre les éléments lorsqu'ils ne sont pas utilisés.



BRANCHEZ-MOI

Venture 75 est en mode d'expédition de protection.
Branchez-le sur un port USB avant de l'utiliser.

BRANCHEZ-MOI: Votre Venture 75 est en mode de transport. Branchez-le sur un port USB avant de l'utiliser.

これを差し込んで下さい Venture 75は保護モードで出荷されています。ご使用前にUSBポートに差し込んで下さい。

STECK MICH ZUERST EIN: Das Venture 75 wird im Schutzmodus geliefert. Vor dem ersten Gebrauch in einen USB-Port einstecken.

CONÉCTEME: El Venture 75 está en modo protector de envío. Conéctelo a un puerto USB antes de usarlo.

Lumières indicatrices du niveau de charge de la batterie

- 1: 25% de charge
- 2: 50% de charge
- 3: 75% de charge
- 4: 100% de charge

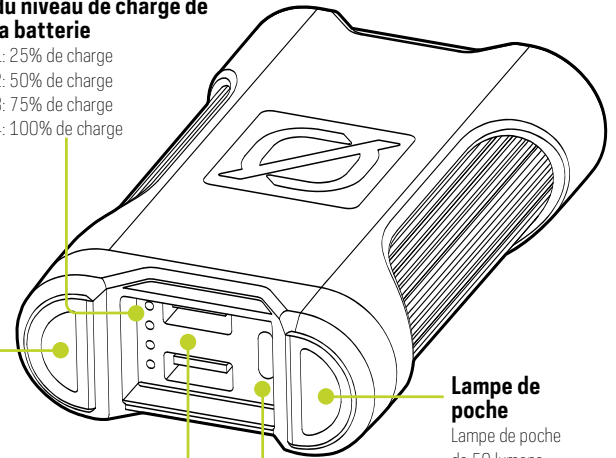

2x ports de sortie USB-A
5V, jusqu'à 3A chacun (15W max),
régulé

**Lampe de
poche**
Lampe de poche
de 50 lumens

Lampe de poche marche/arrêt | Indicateur

Lampe de poche & indicateur de niveau de
charge

Port d'entrée/sortie USB-C
5-20V, jusqu'à 3A (60W max), régulé

RECHARGER AVANT UTILISATION ⚠

Utilisez le câble USB-C inclus pour recharger le Venture 75 à partir d'une source USB active. Utilisez le chargeur USB-C 45 W (vendu séparément) pour une entrée haute vitesse. Un nouveau Venture 75 est livré dans un mode de protection pour empêcher l'auto-décharge, potentiellement causée par de longues périodes d'inactivité, comme l'expédition.

Le Venture 75 ne chargera pas votre équipement tant qu'il ne sera pas branché sur une source USB active.

1. Connectez le câble USB-C à l'entrée et branchez-le sur un port USB actif.
2. Vous saurez qu'il est en charge lorsque les voyants bleus à l'avant s'allument et clignotent. Chaque voyant lumineux bleu représente 25% de la capacité de la batterie. Lorsque la batterie se remplit, l'état de charge clignote en bleu.
3. Le Venture 75 est plein et prêt à fonctionner lorsque toutes les lumières sont allumées.
4. Le Venture 75 permet une décharge et une recharge simultanées afin que vous puissiez charger votre équipement et Venture 75 en même temps.

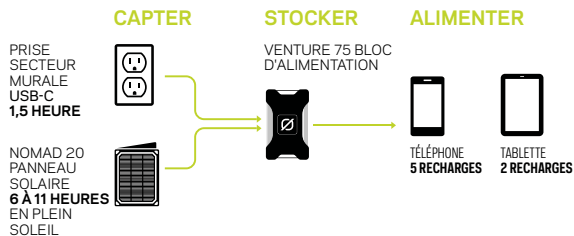

SOLAR READY™

Venture 75 est conçu pour se recharger rapidement à partir des panneaux solaires® Goal Zero Nomad.

1. Connectez l'extrémité USB-C du câble inclus dans le Venture 75 et branchez l'extrémité USB-A dans le port USB à l'arrière du panneau Nomad.
2. Vous saurez qu'il est en charge lorsque les voyants bleus s'allument et clignotent. Chaque voyant lumineux bleu représente 25% de la capacité de la batterie.
3. Le Venture 75 est plein et prêt à fonctionner lorsque toutes les lumières sont allumées en même temps.
4. Les voyants bleus clignotent en fonction du niveau de la batterie. Lors de la charge solaire, utilisez la béquille intégrée pour orienter votre panneau vers le soleil.



RECHARGER VOTRE ÉQUIPEMENT

Le Venture 75 est conçu pour charger des téléphones, des tablettes, des caméras POV et d'autres appareils alimentés par USB. Rechargez jusqu'à 3 appareils simultanément.



PHARE
JUSQU'À 14
RECHARGES



CAMÉRA
EMBARQUÉE
14
RECHARGES



TÉLÉPHONE
5
RECHARGES



TABLETTE
2
RECHARGES



ORDINATEUR
PORTABLE
JUSQU'À 1
RECHARGE

LAMPE DE POCHE

Le Venture 75 a une lampe de poche intégrée de 50 lumens.

ALLUMER/ÉTEINDRE

Appuyez sur le bouton Power Batt/Flashlight pendant 2 secondes pour allumer et éteindre.

CONCEPTION ROBUSTE

L'indice IP67 du Venture 75 vous permet de traverser n'importe quelle aventure, qu'il pleuve ou qu'il fasse beau. Lorsque le bouchon du port étanche est complètement fermé, le Venture 75 est protégé contre la poussière, le sable et les débris et peut résister à une submersion jusqu'à 1 mètre d'eau pendant au moins 30 minutes.

Q: Pourquoi mon équipement ne se recharge-t-il pas ?

R: Vérifiez le niveau de la batterie du Venture 75 en appuyant sur le bouton indicateur d'alimentation de la batterie. Assurez-vous d'utiliser les câbles certifiés fournis avec votre équipement.

Q: Le Venture 75 est-il entièrement étanche ?

R: Oui, avec la porte étanche complètement fermée, l'unité est classée IP67 et est protégée contre la poussière, le sable et les débris, et peut résister à une submersion jusqu'à 1 mètre d'eau pendant au moins 30 minutes.

Q: Comment fonctionne la lampe de poche ?

R: Le Venture 75 a une lampe de poche intégrée de 50 lumens contrôlée par le bouton d'alimentation de l'indicateur d'alimentation de la batterie. Appuyez simplement sur le bouton pendant 2 secondes pour allumer et éteindre la lampe de poche.

Q: Que faire si l'alimentation de mes périphériques USB-C ne circule pas correctement ?

R: Le port USB-C du Venture 75 est bidirectionnel. Cela signifie que le courant peut entrer et sortir. Si le courant ne circule pas comme vous le souhaitez, essayez de débrancher et de rebrancher le câble USB-C une ou deux fois. Cela réenregistrera la direction dans laquelle le courant circule.

Bloc d'alimentation Venture 75

TEMPS DE CHARGE :

GOAL ZERO Nomad 10	11 à 22 heures
--------------------	----------------

GOAL ZERO Nomad 20	6 à 11 heures
--------------------	---------------

GOAL ZERO Nomad 50	6 heures
--------------------	----------

USB-C en source (60W)	1,5 heure
-----------------------	-----------

BATTERIE :

Type de batterie	Li-ion NMC
------------------	------------

Type de batterie	18650 par LG chem
------------------	-------------------

Capacité de la batterie	71.04Wh (11.1V, 6400mAh)
-------------------------	-----------------------------

Capacité d'une seule batterie	19 200 mAh @ 3,7 V
-------------------------------	--------------------

Cycles de vie	Des centaines de cycles
---------------	-------------------------

Durée de conservation	Laissez brancher, ou charger tous les 3 à 6 mois
-----------------------	--

Fusibles	Aucun
----------	-------

Système de gestion	Protection de charge et de batterie faible intégrée
--------------------	---

PORTS :

Port USB (sortie)	5V, jusqu'à 3A chacun (15W max), régulé
-------------------	---

Port USB-C (entrée/sortie)	5-20V, jusqu'à 3A (60W max), régulé
----------------------------	-------------------------------------

GÉNÉRAL :

Classement IP	IP67
---------------	------

Connexion en série	Non
--------------------	-----

Poids	1.27 lbs (577 g)
-------	------------------

Dimensions	15,6 x 9,6 x 2,9 cm (6,1 x 3,8 x 1,1 pouces)
------------	---

Température de fonctionnement	32-113F (0-45C)
-------------------------------	-----------------

Certifications	
----------------	---

Garantie	12 mois
----------	---------

N'oubliez pas d'ACTIVER VOTRE GARANTIE sur goalzero.com/warranty

Schnellladetechnologie trifft auf robuste Langlebigkeit. Im neuen Venture 75 ist das Beste aus beiden Welten vereint. Unsere verbesserte Powerbank mit einer Kapazität von 19200 mAh ist staub- und wasserdicht nach IP67 und verfügt über einen USB-C-Anschluss, der das Aufladen beschleunigt und das Mitführen von Kabeln vereinfacht. Über den 60-W-USB-C-Anschluss mit Power Delivery können Sie Tablets, Laptops und andere USB-C-Geräte aufladen. Über denselben Anschluss können Sie anschließend auch die Powerbank innerhalb von 1,5 Stunden schnell wieder aufladen. Das neue Venture-Design umfasst eine schützende Gummihülle, eine integrierte 50-Lumen-Taschenlampe und einen wasserdichten Stecker, der die Anschlüsse bei Nichtgebrauch vor Feuchtigkeit schützt.



STECK MICH ZUERST EIN

Das Venture 75 wird im Schutzmodus geliefert.
Vor dem ersten Gebrauch in einen USB-Port einstecken.

BRANCHEZ-MOI: Votre Venture 75 est en mode de transport. Branchez-le sur un port USB avant de l'utiliser.

これを差し込んで下さい Venture 75は保護モードで出荷されています。ご使用前にUSBポートに差し込んで下さい。

STECK MICH ZUERST EIN: Das Venture 75 wird im Schutzmodus geliefert. Vor dem ersten Gebrauch in einen USB-Port einstecken.

CONÉCTEME: El Venture 75 está en modo protector de envío. Conéctelo a un puerto USB antes de usarlo.

Batterieleuchtanzeige

- 1: 25 % Ladung
- 2: 50 % Ladung
- 3: 75 % Ladung
- 4: 100 % Ladung

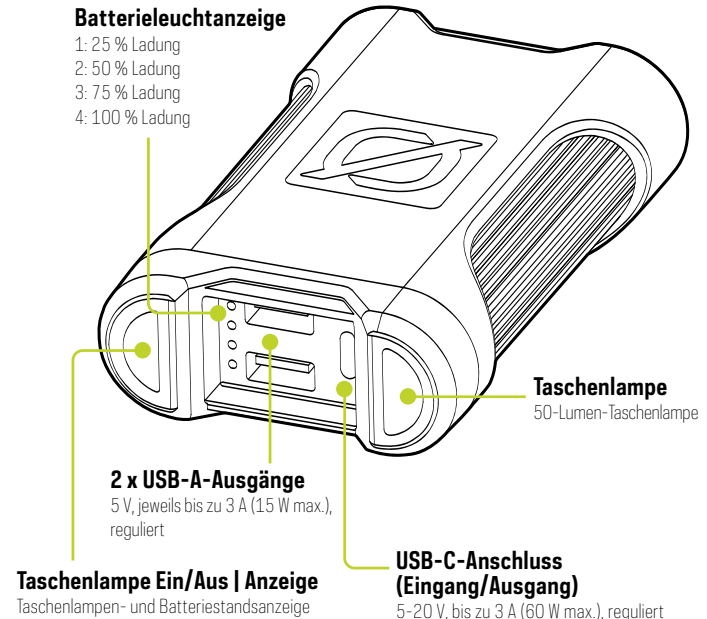

VOR GEBRAUCH AUFLADEN ⚠

Mit dem mitgelieferten USB-C-Kabel können Sie das Venture 75 über eine aktive USB-Quelle aufladen. Das separat erhältliche 45-W-USB-C-Ladegerät bietet einen Hochgeschwindigkeits-Eingang. Das neue Venture 75 verfügt über einen Schutzmodus, um eine Selbstentladung zu verhindern, die durch längere Zeiträume der Inaktivität, z. B. beim Versand, verursacht werden kann.

Das Venture 75 lädt Ihre Geräte erst dann auf, wenn es an eine stromführende USB-Quelle angeschlossen ist.

1. Schließen Sie das USB-C-Kabel an den Eingang an und stecken Sie es in einen stromführenden USB-Anschluss.
2. Das Gerät wird aufgeladen, wenn die blauen Anzeigelampen auf der Vorderseite aufleuchten und blinken. Jede blaue Kontrolllampe steht für 25 % Batteriekapazität. Wenn sich die Batterie füllt, blinkt der Ladezustand blau.
3. Das Venture 75 ist vollgeladen und einsatzbereit, wenn alle Lichter durchgängig leuchten.
4. Das Venture 75 ermöglicht das gleichzeitige Entladen und Aufladen, so dass Sie gleichzeitig Ihre Geräte und das Venture 75 aufladen können.

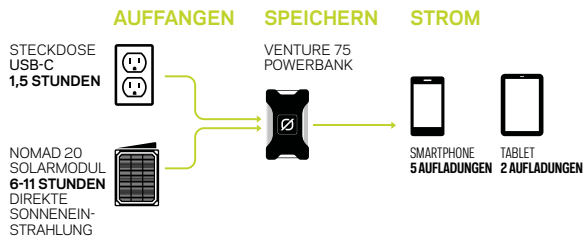

SOLAR READY™

Venture 75 wurde für schnelles Aufladen über die Nomad Solarmodule® von Goal Zero entwickelt.

1. Schließen Sie das USB-C-Ende des mitgelieferten Kabels an das Venture 75 an und stecken Sie das USB-A-Ende in den USB-Anschluss an der Rückseite des Nomad-Panels.
2. Der Ladevorgang wird durch das Aufleuchten und Blinken der blauen Kontrolllampen angezeigt. Jede blaue Kontrolllampe steht für 25 % Batteriekapazität.
3. Das Venture 75 ist vollgeladen und einsatzbereit, wenn alle Lichter gleichzeitig durchgängig leuchten.
4. Die blauen Kontrolllampen blinken je nach Batterieladestand. Nutzen Sie den eingebauten Ständer, um das Solarmodul während der Solaraufladung zur Sonne hin auszurichten.



NOMAD 10
11-22 STUNDEN



NOMAD 20
6-11 STUNDEN



NOMAD 50
6 STUNDEN

GERÄTE AUFLADEN

Das Venture 75 ist zum Laden von Smartphones, Tablets, POV-Kameras und anderen USB-betriebenen Geräten vorgesehen. Sie können bis zu 3 Geräte gleichzeitig laden.



STIRNLAMPE
BIS ZU 14
AUFLADUNGEN



POV-KAMERA
14
AUFLADUNGEN



SMARTPHONE
5
AUFLADUNGEN



TABLET
2.
AUFLADUNGEN



LAPTOP
BIS ZU 1
AUFLADUNG

TASCHENLAMPE

Das Venture 75 verfügt über eine eingebaute Taschenlampe mit 50 Lumen Leuchtkraft.

EIN-/AUSSCHALTEN

Zum Ein-/Ausschalten halten Sie die Taste für die Batteriestandsanzeige/Taschenlampe 2 Sekunden lang gedrückt.

ROBUSTES DESIGN

Da das Venture 75 die Bedingungen für die Schutzklasse IP67 erfüllt, sind Sie für jedes Abenteuer gewappnet, egal ob es regnet oder die Sonne scheint. Wenn die wasserdichte Abdeckung des Anschlusses vollständig geschlossen ist, ist das Venture 75 gegen Staub, Sand und Schmutz geschützt und kann mindestens 30 Minuten lang in bis zu 1 Meter tiefes Wasser getaucht werden.

HÄUFIG GESTELLTE FRAGEN

Frage: Weshalb werden meine Geräte nicht aufgeladen?

Antwort: Überprüfen Sie den Batteriestand des Venture 75 durch Drücken der Batteriestandsanzeigetaste. Benutzen Sie unbedingt die zertifizierten Kabel, die mit Ihren Geräten geliefert wurden.

Frage: Ist das Venture 75 vollständig wasserdicht?

Antwort: Ja, bei vollständig geschlossener Abdeckung ist das Gerät gemäß IP67 gegen Staub, Sand und Schmutz geschützt und kann mindestens 30 Minuten lang in bis zu 1 Meter tiefes Wasser getaucht werden.

Frage: Wie funktioniert die Taschenlampe?

Antwort: Das Venture 75 hat eine eingebaute, 50 Lumen starke Taschenlampe, die über die Batteriestandsanzeigetaste gesteuert wird. Halten Sie die Taste einfach 2 Sekunden lang gedrückt, um die Taschenlampe ein- und auszuschalten.

Frage: Was ist, wenn der Strom von meinen USB-C-Geräten nicht in die richtige Richtung fließt?

Antwort: Der USB-C-Anschluss des Venture 75 ist bi-direktional. Das heißt, dass der Strom in beide Richtungen fließen kann. Wenn der Strom nicht in die gewünschte Richtung fließt, versuchen Sie, das USB-C-Kabel ein- oder zweimal aus- und wieder einzustecken. Dadurch wird die Richtung, in der der Strom fließt, neu registriert.

TECHNISCHE SPEZIFIKATIONEN

Venture 75 Powerbank

LADEZEITEN:

GOAL ZERO Nomad 10 11-22 Std.

GOAL ZERO Nomad 20 6-11 Std.

GOAL ZERO Nomad 50 6 Std.

USB-C-Quelle (60W) 1,5 Std.

BATTERIE:

Zellchemie Li-Ion NMC

Akkutyp 18650. Hersteller:
LG chem

Zellenkapazität 71,04Wh
(11,1V, 6400mAh)

Einzelzellen-Kapazität 19200 mAh bei 3,7 V

Lebenszyklen Hunderte von Zyklen

Haltbarkeit An eine Stromquelle
angeschlossen lassen
oder alle 3 bis 6 Monate
aufladen

Sicherungen Keine

Verwaltungssystem Integrierter Ladeschutz
und Schutz bei schwacher
Batterie

ANSCHLÜSSE:

USB-Anschluss (Ausgang) 5 V, jeweils bis zu 3 A
(15 W max.), reguliert

USB-C Anschluss
(Eingang/Ausgang) 5-20 V, bis zu 3 A
(60 W max.), reguliert

ALLGEMEIN:

Schutzgrad IP67

Verkettbar Nein

Gewicht 1.27 lbs (577 g)

Abmessungen 15,6 x 9,6 x 2,9 cm

Betriebstemperatur 32-113F (0-45C)

Zertifizierungen      

Garantie 12 Monate

AKTIVIEREN SIE IHRE GARANTIE unbedingt
auf goalzero.com/warranty

La tecnología de carga rápida se combina con una durabilidad resistente. La nueva Venture 75 combina lo mejor de ambos mundos. Nuestra batería portátil mejorada de 19200 mAh cuenta con una clasificación IP67 a prueba de agua/polvo y un puerto USB-C diseñado para acelerar la carga y optimizar el transporte de cables. Encienda tabletas, ordenadores portátiles y otros dispositivos USB-C utilizando el puerto de suministro de energía USB-C de 60 W, luego use el mismo puerto para recargar rápidamente la batería portátil en 1,5 horas. El diseño Fresh Venture cuenta con una funda protectora de goma, una linterna integrada de 50 lúmenes y un enchufe impermeable que protege sus puertos contra los elementos cuando no está en uso. El diseño Fresh Venture cuenta con una funda protectora de goma, una linterna integrada de 50 lúmenes y un enchufe impermeable que protege sus puertos contra los elementos cuando no está en uso.



CONÉCTEME

La Venture 75 está en modo protector de envío.
Conéctela a un puerto USB antes de usarla.

BRANCHEZ-MOI: Votre Venture 75 est en mode de transport. Branchez-le sur un port USB avant de l'utiliser.

これを差し込んで下さい。Venture 75は保護モードで出荷されています。ご使用前にUSBポートに差し込んで下さい。

STECK MICH ZUERST EIN: Das Venture 75 wird im Schutzmodus geliefert. Vor dem ersten Gebrauch in einen USB-Port einstecken.

CONÉCTEME: La Venture 75 está en modo protector de envío. Conéctela a un puerto USB antes de usarlo.

Luces indicadoras de baterías

- 1: carga al 25 %
- 2: carga al 50 %
- 3: carga al 75 %
- 4: carga al 100 %

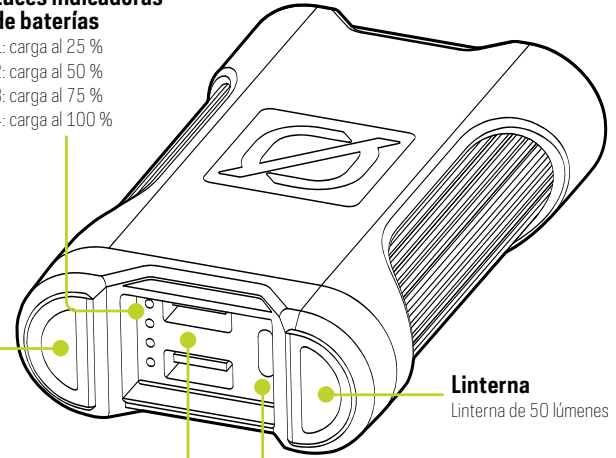

Linterna
Linterna de 50 lúmenes

Dos puertos USB-A de salida

5 V, hasta 3A cada uno
(15W máx.), regulado

Puerto USB-C de entrada/salida

5-20V, hasta 3A (60W máx.), regulados

Indicador On/Off de la linterna

Indicador de nivel de batería y linterna

CARGAR ANTES DE USAR ⚠

Utilice el cable USB-C incluido para cargar Venture 75 desde una fuente USB en vivo. Utilice el cargador USB-C de 45W (se vende por separado) para una entrada de alta velocidad. Una nueva Venture 75 viene en modo de protección para evitar la autodescarga, potencialmente causada por largos períodos de inactividad, como durante el envío.

La Venture 75 no cargará su equipo hasta que esté conectado a una fuente USB en vivo.

1. Conecte el cable USB-C a la entrada y conéctelo a un puerto USB activo.
2. Sabrá que se está cargando cuando las luces indicadoras azules, en la parte delantera, se iluminen y parpadéen. Cada luz indicadora azul representa el 25% de la capacidad de la batería. A medida que la batería se llena, el estado de carga parpadeará en azul.
3. La Venture 75 está completa y lista para funcionar cuando todas las luces estén fijas.
4. La Venture 75 permite la descarga y recarga simultáneas para que pueda cargar su equipo y la Venture 75 al mismo tiempo.

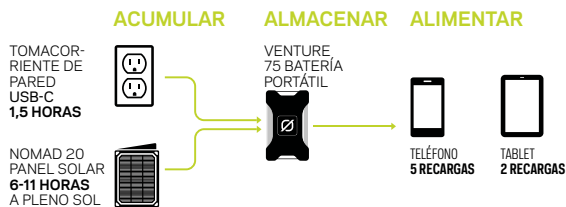

SOLAR READY™

Venture 75 está diseñada para cargarse rápidamente desde los® paneles solares Goal Zero Nomad.

1. Conecte el extremo USB-C del cable incluido en la Venture 75 y enchufe el extremo USB-A en el puerto USB en la parte posterior del panel Nomad.
2. Sabrá que se está cargando cuando las luces indicadoras azules se iluminen y parpadéen. Cada luz indicadora azul representa el 25% de la capacidad de la batería.
3. La Venture 75 está completa y lista para funcionar cuando todas las luces estén fijas.
4. Las luces indicadoras azules parpadearán según el nivel de la batería. Cuando cargue con energía solar, use el pie de apoyo incorporado para orientar su panel hacia el sol.



NOMAD 10
11-22 HORAS



NOMAD 20
6-11 HORAS



NOMAD 50
6 HORAS

CARGUE SU EQUIPO

La Venture 75 está diseñada para cargar teléfonos, tabletas, cámaras POV y otros dispositivos alimentados por USB. Cargue hasta tres dispositivos simultáneamente.



LINTERNA DE CABEZA
HASTA 14
RECARGAS



CÁMARA POV
14
RECARGAS



TELÉFONO
5
RECARGAS



TABLETA
2
RECARGAS



ORDENADOR
PORTÁTIL
HASTA 1
RECARGA

LINTERNA

La Venture 75 viene con una linterna incorporada de 50 lúmenes.

ENCENDER/APAGAR

Presione el botón Power Batt/Flashlight durante dos segundos para encender y apagar.

DISEÑO RESISTENTE

La clasificación IP67 de la Venture 75 le permite afrontar cualquier aventura, llueva o haga sol. Cuando el tapón del puerto, resistente al agua, está completamente cerrado, la Venture 75 está protegida contra el polvo, la arena y los escombros y puede soportar la inmersión de hasta 1 metro de agua durante al menos 30 minutos.

P: ¿Por qué mi equipo no se carga?

R: Verifique el nivel de la batería de la Venture 75 presionando el botón indicador de energía de la batería. Asegúrese de utilizar los cables certificados que vienen con su equipo.

P: ¿La Venture 75 es completamente impermeable?

R: Sí, con la puerta impermeable completamente cerrada, la unidad tiene una clasificación IP67 y está protegida contra el polvo, la arena y los escombros y puede soportar la inmersión hasta 1 metro de agua durante al menos 30 minutos.

P: ¿Cómo funciona la linterna?

R: La Venture 75 tiene una linterna incorporada de 50 lúmenes controlada por el botón de encendido del indicador Power Battery. Simplemente presione el botón hacia abajo durante dos segundos para encender y apagar la linterna.

P: ¿Qué sucede si la energía de mis dispositivos USB-C no fluye correctamente?

R: El puerto USB-C de la Venture 75 es bidireccional. Lo que significa que la energía puede fluir hacia adentro y hacia afuera. Si la energía no fluye como le gustaría, intente desconectar y volver a conectar el cable USB-C una o dos veces. Esto volverá a registrar la dirección en la que fluye la energía.

Batería portátil Venture 75

TIEMPOS DE CARGA:

GOAL ZERO Nomad 10	11-22 horas
GOAL ZERO Nomad 20	6-11 horas
GOAL ZERO Nomada 50	6 horas
Fuente USB-C (60W)	1,5 horas



BATERÍA:

Química de celdas	Li-ion NMC
Tipo de célula	18650 de LG chem
Capacidad de la celda	71.04Wh (11.1V, 6400mAh)
Capacidad celda individual	19200mAh @ 3,7V
Ciclos de vida	Cientos de ciclos
Vida útil	Manténgala enchufada o cárguela cada 3-6 meses
Fusibles	Ninguno
Sistema de administración	Carga y protección de batería baja integrada

PUERTOS:

Puerto USB (salida)	5 V, hasta 3A cada uno (15W máx.), regulado
Puerto USB-C (entrada/salida)	5-20V, hasta 3A (60W máx.), regulados

GENERAL:

Clasificación del IP	IP67
Conectable en serie	No
Peso	1.27 lbs (577 g)
Dimensiones	6,1 x 3,8 x 1,1 pulg (15,6 x 9,6 x 2,9 cm)
Temperatura en funcionamiento	32-113F (0-45C)
Certificaciones	 
Garantía	12 meses

Asegúrese de **ACTIVAR SU GARANTÍA** en goalzero.com/warranty

La tecnologia di ricarica rapida si sposa con la durabilità nel tempo. Il nuovo Venture 75 combina il meglio dei due mondi. Il nostro power bank aggiornato da 19200 mAh ha una classificazione IP67 resistente alla polvere e all'acqua e una porta USB-C progettata per velocizzare la ricarica e semplificare il trasporto dei cavi. Il dispositivo alimenta tablet, laptop e altri dispositivi USB-C usando la porta USB-C Power Delivery da 60W. Utilizzando la stessa porta è possibile ricaricare rapidamente il power bank in 1,5 ore. Il nuovo design di Venture presenta un guscio protettivo in gomma, una torcia integrata da 50 lumen e una spina impermeabile che protegge le porte dagli elementi quando non sono in uso.



COLLEGAMI

Venture 75 è in modalità 'protezione per la spedizione'.
Inserire la spina in una porta USB prima dell'uso.

BRANCHEZ-MOI: Votre Venture 75 est en mode de transport. Branchez-le sur un port USB avant de l'utiliser. Branchez-le sur un port USB avant de l'utiliser.

これを差し込んで下さい。Venture 75は保護モードで出荷されています。ご使用前にUSBポートに差し込んで下さい。

STECK MICH ZUERST EIN: Das Venture 75 wird im Schutzmodus geliefert. Vor dem ersten Gebrauch in einen USB-Port einstecken.

CONÉCTEME: El Venture 75 está en modo protector de envío. Conéctelo a un puerto USB antes de usarlo.

Indicatori luminosi della batteria

- 1: 25% di carica
- 2: 50% di carica
- 3: 75% di carica
- 4: 100% di carica

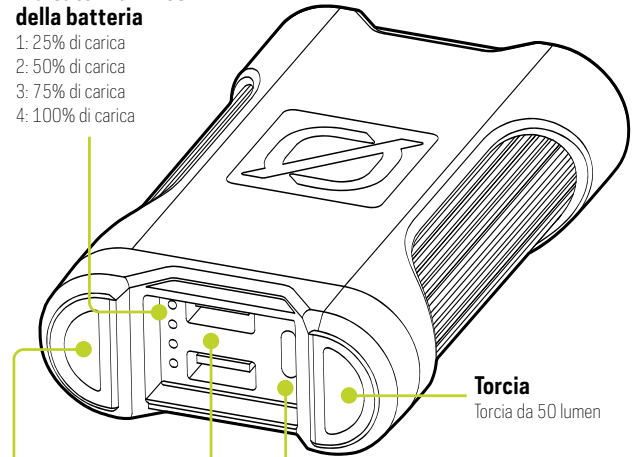

2 porte di uscita USB-A

5V, fino a 3A ciascuno (15W max), stabilizzati

Torcia

Torcia da 50 lumen

Torcia elettrica On/Off | Indicatore

Torcia e indicatore del livello della batteria

Porta di ingresso/uscita USB-C

5-20 V, fino a 3 A (60 W max), regolato

CARICARE PRIMA DELL'USO ⚠

Utilizzare il cavo USB-C incluso per caricare Venture 75 da una fonte USB in tensione. Usa il caricatore USB-C da 45W (venduto separatamente) per un caricamento ad alta velocità. Un nuovo Venture 75 è dotato di una modalità protettiva per prevenire l'autoscarica, potenzialmente causata da lunghi periodi di inattività, come durante la spedizione.

Il Venture 75 caricherà la vostra apparecchiatura solo quando sarà collegato a una fonte USB in tensione.

1. Collegare il cavo USB-C all'ingresso e inseriscilo in una porta USB in tensione.
2. Le spie blu accese e lampeggianti sulla parte anteriore indicano che l'apparecchio è in carica. Ogni indicatore luminoso blu rappresenta il 25% della capacità della batteria. Mentre la batteria si carica, lo stato di carica lampeggia in blu.
3. Venture 75 è carico e pronto ad essere utilizzato quando tutte le luci sono fisse.
4. Il Venture 75 permette di scaricare e ricaricare simultaneamente, in modo da poter caricare il tuo apparecchio e il Venture 75 allo stesso tempo.

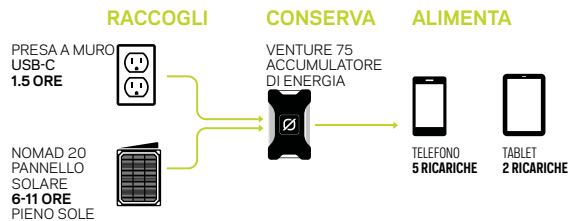

SOLAR READY™

Venture 75 è progettato per caricare rapidamente l'energia in entrata dai pannelli solari Nomad di® Goal Zero.

1. Collegare l'estremità USB-C del cavo incluso nel Venture 75 e inserire l'estremità USB-A nella porta USB sul retro del pannello Nomad.
2. Le spie blu accese e lampeggianti indicano che l'apparecchio è in carica. Ogni indicatore luminoso blu rappresenta il 25% della capacità della batteria.
3. Venture 75 è carico e pronto ad essere utilizzato quando tutte le luci sono fisse.
4. Gli indicatori luminosi blu lampeggiano a seconda del livello della batteria. Quando si carica con la luce solare, usare il cavalletto incorporato per angolare il pannello verso il sole.



CARICARE L'APPARECCHIO

Il Venture 75 è progettato per caricare telefoni, tablet, fotocamere POV e altri dispositivi alimentati via USB. Carica fino a 3 dispositivi simultaneamente.



LAMPADA FRONTALE
FINO A 14
RICARICHE



TELECAMERA POV
14
RICARICHE



TELEFONO
5
RICARICHE



TABLET
2
RICARICHE



LAPTOP
FINO A 1
RICARICA

TORCIA

Il Venture 75 è dotato di una torcia integrata da 50 lumen.

ACCENSIONE / SPEGNIMENTO

Premere il pulsante Power Batt/Flashlight per 2 secondi per accendere e spegnere.

DESIGN ROBUSTO

Il grado di protezione IP67 del Venture 75 permetterà di affrontare qualsiasi avventura, con il bello o il cattivo tempo. Con la porta impermeabile completamente chiusa, il Venture 75 è protetto da polvere, sabbia e detriti, e può resistere all'immersione in acqua fino a una profondità di 1 metro per almeno 30 minuti.

DOMANDE FREQUENTI

D: Perché la mia apparecchiatura non si carica?

R: Controllare il livello della batteria di Venture 75 premendo il pulsante dell'indicatore della batteria di alimentazione. Assicurarsi di utilizzare i cavi autorizzati forniti con l'apparecchio.

D: Il Venture 75 è completamente impermeabile all'acqua?

R: Sì, con la porta impermeabile completamente chiusa, l'unità è classificata IP67 ed è protetta da polvere, sabbia e detriti, e può resistere all'immersione in acqua fino a una profondità di 1 metro per almeno 30 minuti.

D: Come funziona la torcia?

R: Il Venture 75 ha una torcia incorporata da 50 lumen controllata dal pulsante di accensione dell'indicatore della batteria. Basta premere il pulsante per 2 secondi per accendere e spegnere la torcia.

D: Cosa succede se l'alimentazione dei miei dispositivi USB-C non passa nel modo corretto?

R: La porta USB-C sul Venture 75 è bidirezionale. Il che significa che l'energia può scorrere in entrata e in uscita. Se l'alimentazione non scorre come si vorrebbe, provare a scollegare e ricollegare il cavo USB-C una o due volte. Questo registrerà nuovamente la direzione del flusso di corrente.

CARATTERISTICHE TECNICHE

Accumulatore di energia VENTURE 75

TEMPI DI RICARICA:

Nomad 10 di GOAL ZERO	11-22 ore
Nomad 20 di GOAL ZERO	6-11 ore
Nomad 50 di GOAL ZERO	6 ore
Sorgente USB-C (60W)	1.5 ore





BATTERIA:

Chimica delle celle	agli ioni di litio NMC (nichel, manganese, cobalto, N.d.T.)
Tipo di cella	18650 di LG chem
Capacità della cella	71.04Wh (11.1V, 6400mAh)
Capacità di una singola cella	19200mAh a 3.7V
Cicli vitali	Centinaia di cicli
Durata di conservazione (dalla produzione alla vendita)	Tenere collegato, o ricaricare ogni 3-6 mesi
Fusibili	Nessuno
Sistema di gestione	Ricarica e protezione a basso consumo integrata

PORTE:

Porta USB (Uscita)	5V, fino a 3A ciascuno (15W max), stabilizzati
Porta USB-B (entrata/uscita)	5-20 V, fino a 3 A (60 W max), regolato

GENERALE:

Valutazione IP	IP67
Incatenabile	No
Peso	1.27 lbs (577 g)
Dimensioni	6.1 x 3.8 x 1.1 in (15.6 x 9.6 x 2.9 cm)
Temperatura d'uso	32-113F (0-45C)
Certificazioni	   
Garanzia	12 mesi

Assicurarsi di **ATTIVARE LA GARANZIA** su goalzero.com/warranty

A tecnologia de carregamento rápido aliada à durabilidade robusta. O novo Venture 75 combina o melhor dos dois mundos. O nosso carregador portátil de 19200 mAh atualizado apresenta uma classificação IP67 à prova de pó/água e uma porta USB-C projetada para acelerar o carregamento e otimizar o transporte de cabos. Ligue tablets, laptops e outros dispositivos USB-C usando a porta de entrada de energia USB-C de 60 W e, em seguida, use a mesma porta para recarregar rapidamente o carregador portátil em 1,5 horas. O novo design do Venture apresenta uma capa protetora de borracha, lanterna de 50 lúmen integrada e um plugue à prova de água que protege as suas entradas contra os elementos quando não estão em uso.



LIGUE-ME

O Venture 75 está em modo de envio de proteção.
Conecte-o a uma entrada USB antes de usar.

BRANCHEZ-MOI: Votre Venture 75 est en mode de transport. Branchez-le sur un port USB avant de l'utiliser.

これを差し込んで下さい Venture 75は保護モードで出荷されています。ご使用前にUSBポートに差し込んで下さい。

STECK MICH ZUERST EIN: Das Venture 75 wird im Schutzmodus geliefert. Vor dem ersten Gebrauch in einen USB-Port einstecken.

CONÉCTEME: El Venture 75 está en modo protector de envío. Conéctelo a un puerto USB antes de usarlo.

Luzes do Indicador de Bateria

- 1: 25% carga
- 2: 50% carga
- 3: 75% carga
- 4: 100% carga

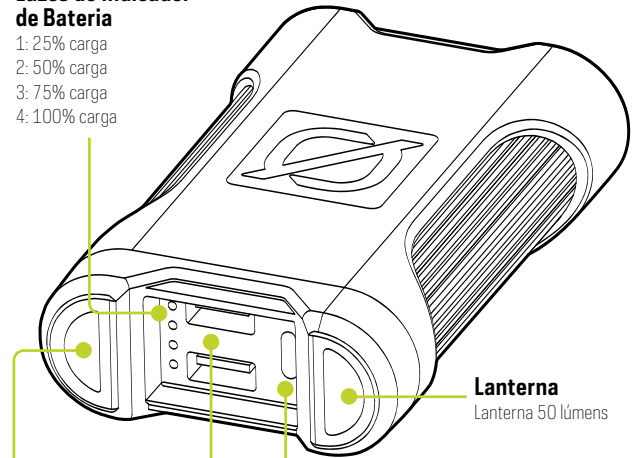

2 portas de saída USB-A

5V, até 3A cada (15W máx.), regulado

Lanterna

Lanterna 50 lúmens

Lanterna ligada/desligada | Indicador

Lanterna e indicador de nível de bateria

Porta de entrada/saída USB-C

5-20V, até 3A (60W máx.), regulado

CARREGAR ANTES DE USAR ⚠

Use o cabo USB-C incluído para carregar o Venture 75 de uma fonte USB ativa. Use o carregador USB-C de 45 W (vendido separadamente) para uma entrada de alta velocidade. O novo Venture 75 vem em modo de proteção para evitar autodescarga, potencialmente causada por longos períodos de inatividade, como o transporte.

O Venture 75 não carregará seu equipamento até que ele seja conectado a uma fonte USB ativa.

1. Conecte o cabo USB-C à entrada e conecte-o a uma porta USB ativa.
2. Você saberá que está a carregar quando as luzes indicadoras azuis na frente se iluminarem e piscarem. Cada luz indicadora azul representa 25% da capacidade da bateria. O estado de carga pisca em azul à medida que a bateria carrega.
3. O Venture 75 está inteiramente carregado e pronto para funcionar quando todas as luzes estão estáveis.
4. O Venture 75 permite descarga e recarga simultâneas para que você possa carregar o seu equipamento e o Venture 75 ao mesmo tempo.

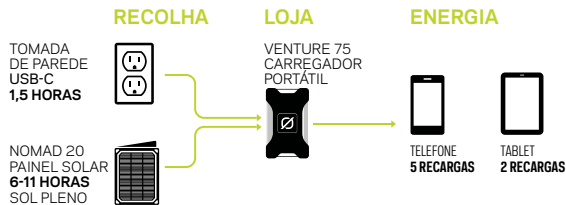

SOLAR READY™

O Venture 75 foi projetado para carregar rapidamente a partir dos painéis solares Goal Zero Nomad®.

1. Conecte a extremidade USB-C do cabo incluído no Venture 75 e conecte a extremidade USB-A na porta USB na parte traseira do painel Nomad.
2. Você saberá que está a carregar quando as luzes indicadoras azuis acenderem e piscarem. Cada luz indicadora azul representa 25% da capacidade da bateria.
3. O Venture 75 está carregado e pronto para funcionar quando todas as luzes estão todas estáveis.
4. As luzes indicadoras azuis piscarão de acordo com o nível da bateria. Ao carregar a partir da energia solar, use o suporte integrado para inclinar o painel na direção do sol.



NOMAD 10
11-22 HORAS



NOMAD 20
6-11 HORAS



NOMAD 50
6 HORAS

CARREGUE O SEU EQUIPAMENTO

O Venture 75 foi projetado para carregar telefones, tablets, câmaras POV e outros dispositivos alimentados por USB. Carregue até 3 dispositivos simultaneamente.



FAROL
ATÉ 14
RECARGAS



CÂMARA POV
14
RECARGAS



TELEFONE
5
RECARGAS



TABLET
2
RECARGAS



LAPTOP
ATÉ 1
RECARRGAR

LANTERNA

O Venture 35 vem com uma lanterna embutida de 50 lúmens.

LIGAR/DESLIGAR

Pressione o botão Power Batt/Flashlight por durante segundos para ligar e desligar.

DESIGN ROBUSTO

A classificação IP67 do Venture 75 permite que você supere qualquer aventura, faça chuva ou faça sol. Quando o plugue da porta à prova de água está totalmente fechado, o Venture 75 fica protegido contra pó, areia e detritos, e pode resistir à submersão de até 1 metro de água durante pelo menos 30 minutos.

QUESTÕES COLOCADAS FREQUENTEMENTE

P: Porque é que o meu equipamento não está a carregar?

R: Verifique o nível da bateria do Venture 75 pressionando o botão indicador de energia da bateria. Certifique-se de usar os cabos certificados que acompanham o seu equipamento.

P: O Venture 75 é totalmente à prova de água?

R: Sim, com a porta à prova de água totalmente fechada, a unidade é classificada em IP67 e é protegida contra pó, areia e detritos, e pode resistir à submersão de até 1 metro de água durante pelo menos 30 minutos.

P: Como funciona a lanterna?

R: O Venture 75 tem uma lanterna embutida de 50 lúmens controlada pelo botão de energia indicador de bateria. Basta pressionar o botão durante 2 segundos para ligar e desligar a lanterna.

P: E se a energia dos meus dispositivos USB-C não estiver a fluir da maneira correta?

R: A porta USB-C no Venture 75 é bidirecional. Significando que o poder pode fluir para dentro e para fora. Se a energia não estiver a fluir da maneira que gostaria, tente desconectar e reconectar o cabo USB-C uma ou duas vezes. Isso registrará novamente a direção em que a energia está a fluir.

ESPECIFICAÇÕES TÉCNICAS

Carregador portátil Venture 75

TEMPOS DE CARREGAMENTO:

GOAL ZERO Nomad 10 11-22 horas

GOAL ZERO Nomad 20 6-11 horas

GOAL ZERO Nomad 50 6 horas

Fonte USB-C (60W) 1,5 horas

BATERIA:

Química das células Li-ion NMC

Tipo de célula 18650 by LG chem

Capacidade da célula 71.04Wh
(11.1V, 6400mAh)

Capacidade da célula única 19200mAh @ 3.7V

Ciclos de utilização Centenas de ciclos

Vida útil Mantenha ligado,
ou carregue a cada
3-6 meses

Fusíveis Nenhum

Sistema de Gestão Carregamento e proteção
incluída em baixa bateria.

LIGAÇÕES:

Porta USB (saída) 5V, até 3A cada
(15W máx.), regulado

Porta USB-C (entrada/saída) 5-20V, até 3A
(60W máx.), regulado

GERAL:

Rating IP IP67

Ligado Não

Peso 1.27 lbs (577 g)

Dimensões 6.1 x 3.8 x 1.1 in
(15.6 x 9.6 x 2.9 cm)

Temperatura operacional
de uso 32-113F (0-45C)

Certificações  

Garantias 12 meses

Certifique-se de ATIVAR A SUA
GARANTIA em goalzero.com/warranty

急速充電技術は、頑丈な耐久性を備えています。新しいベンチャー75は、両方の長所が融合されたものになっています。アップグレードされた19200mAh/パワーバンクは、IP67防塵/防水定格と、充電を高速化し、ケーブルの持ち運びを合理化するように設計されたUSB-Cポートを備えています。60W USB-C 電力供給ポートを使用してタブレット、ラップトップ、およびその他のUSB-Cデバイスの電源を投入し、同じポートを使用して1.5時間でパワーバンクをすばやく充電します。フレッシュなベンチャーデザインは、保護ゴムスリーブ、統合された50ルーメンの懐中電灯、および使用されていないときにエレメントからポートを保護する防水プラグを備えています。



プラグ・ミー・イン

ベンチャー75は保護輸送モードです 使用する前にUSBポートに接続してください。

BRANCHEZ-MOI: Votre Venture 35 est en mode de transport. Branchez-le sur un port USB avant de l'utiliser.

これを差し込んで下さい Venture 75は保護モードで出荷されています。ご使用前にUSBポートに差し込んで下さい。

STECK MICH ZUERST EIN: Das Venture 75 wird im Schutzmodus geliefert. Vor dem ersten Gebrauch in einen USB-Port einstecken.

CONÉCTEME: El Venture 75 está en modo protector de envío. Conéctelo a un puerto USB antes de usarlo.

バッテリーインジケーターライト

- 1: 充電25%
- 2: 充電50%
- 3: 充電75%
- 4: 充電100%

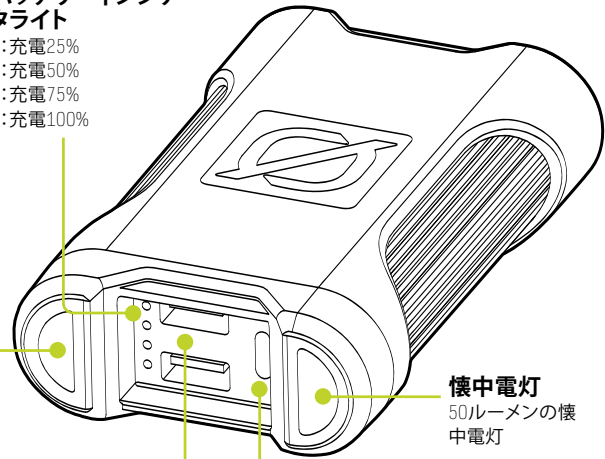

懐中電灯
50ルーメンの懐中電灯

USB-A出力ポート2個
5V、各最大3A (最大15W)、安定化

USB-C入力/出力ポート
5-20V、3A まで (最大 60W)、安定化

懐中電灯のオン/オフインジケーター

懐中電灯 & バッテリーレベルインジケーター

使用前に充電する ▲

付属のUSB-Cケーブルを使用して、ライブUSBソースからベンチャー75を充電します。高速入力には45W USB-C充電器(別売)をご利用ください。新しいベンチャー35は、輸送などの長期間使用されない状態によって引き起こされる可能性のある自己放電を防ぐための保護モードになっています。

ベンチャー75は、ライブUSBソースに接続されるまでギアを充電しません。

1. USB-Cケーブルを入力に接続し、ライブUSBポートに接続します。
2. 前面の青いインジケータライトが点灯して点滅すると、充電中であることがわかります。青いインジケータライトはそれぞれ、25%のバッテリー容量を表しています。バッテリーが充電されると、充電状態が青色に点滅します。
3. ベンチャー75は満充電で、すべてのライトが点灯したらすぐに使用可能です。
4. ベンチャー75では、放電と再充電を同時に行うことができるため、ギアとベンチャー75を同時に充電できます。

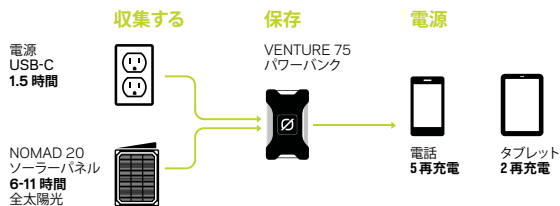

SOLAR READY™

ベンチャー75は、Goal Zero Nomad® ソーラーパネルからすばやく充電できるように設計されています。

1. 付属のケーブルのUSB-C側をベンチャー75に接続し、USB-A側をNomad/パネルの背面にあるUSBポートに接続します。
2. 青いインジケータライトが点灯して点滅すると、充電中であることがわかります。青いインジケータライトはそれぞれ、25%のバッテリー容量を表しています。
3. ベンチャー75は満充電で、すべてのライトが点灯したらすぐに使用可能です。
4. 電池残量に応じて青色のインジケータライトが点滅します。ソーラーから充電する場合は、内蔵のキックスタンドを使用して、パネルを太陽に向けて傾けます。



NOMAD 10
11~22時間



NOMAD 20
6-11時間



NOMAD 50
6時間

ギアを充電する

ベンチャー75は、電話、タブレット、POVカメラ、およびその他のUSB電源デバイスを充電するように設計されています。最大3台のデバイスを同時に充電します。



ヘッドランプ
最大14個まで
最充電



POVカメラ
14
最充電



電話
5
最充電



タブレット
2
最充電



ノートブックパソコン
最大1つまで
再充電

懐中電灯

ベンチャー75には、50ルーメンの懐中電灯が組み込まれています。

オン/オフを切り替える

パワーバット/懐中電灯ボタンを2秒間押し、オンとオフを切り替えます。

頑丈なデザイン

ベンチャー75のIP67規格により、どのような環境下であっても、晴雨を問わず電力を供給できます。防水ポートプラグが完全に閉じている場合、ベンチャー75はほこり、砂、デブリから保護され、最大1メートルの水に少なくとも30分間浸水しても耐えることができます。

Q: なぜ私のギアは充電されないのですか？

A: パワーバッテリーインジケータボタンを押して、ベンチャー75のバッテリーレベルを確認します。ギアに付属の認定ケーブルを使用するようにしてください。

Q: ベンチャー75は完全防水ですか？

A: はい。防水ドアを完全に閉じた状態で、ユニットの定格はIP67で、ほこり、砂、デブリから保護されており、最大1メートルの水に少なくとも30分間浸水しても耐えることができます。

Q: 懐中電灯はどのように機能しますか？

A: ベンチャー75には、バッテリーインジケータの電源ボタンで制御される50ルーメンの懐中電灯が組み込まれています。ボタンを2秒間押すだけで、懐中電灯のオンとオフを切り替えることができます。

Q: USB-Cデバイスからの電力が正しい方向に流れていない場合はどうなりますか？

A: ベンチャー75のUSB-Cポートは双方向です。すなわち、電力は出入りの両方が可能です。希望どおりに電力が流れていない場合は、USB-Cケーブルを1〜2回抜き差ししてみてください。これにより、電力が流れる方向が再登録されます。

ベンチャー75パワーバンク

充電時間:

GOAL ZERO Nomad 10	11-22時間
--------------------	---------

GOAL ZERO Nomad 20	6~11 時間
--------------------	---------

GOAL ZERO Nomad 50	6 時間
--------------------	------

USB-Cソース (60W)	1.5時間
----------------	-------

バッテリー:

セルの種類	リチウムイオン NMC
-------	-------------

セルタイプ	LG chemから18650
-------	----------------

セル容量	71.04Wh (11.1V, 6400mAh)
------	--------------------------

単一セル容量	19200mAh @ 3.7V
--------	-----------------

充電寿命	数百回の充電が可能
------	-----------

バッテリーの保存期間	充電したままにするか、3~6か月ごとに充電してください
------------	-----------------------------

ヒューズ	なし
------	----

管理システム	充電・バッテリー低下保護機能内蔵
--------	------------------

ポート:

USB ポート (出力)	5V, 各最大3A (最大15W)、安定化
--------------	-----------------------

USB-Cポート (入出力)	5-20V, 3A まで (最大 60W)、安定化
----------------	---------------------------

全般:

IP定格	IP67
------	------

チェーン接続	不可
--------	----

重量	1.27 lbs (577 g)
----	------------------

寸法	6.1 x 3.8 x 1.1 in (15.6 x 9.6 x 2.9 cm)
----	--

動作温度	32-113F (0-45C)
------	-----------------

認定	CE, FCC, RoHS
----	---------------

保証	12ヶ月
----	------

必ず goalzero.com/warranty で保証を有効にしてください

Nopea latausteknologia yhdessä jämäkän kestävyuden kanssa. Uusi Venture 75:ssä yhdistyvät kaikki parhaat puolet. Uudistetussa 19200 mAh:n varavirtalähteessämme on IP67-pöly- ja vesitiiviysluokka ja USB-C-liitäntä, joka on suunniteltu nopeuttamaan lataamista ja yksinkertaistamaan kaapelin viientä. Anna virtaa tableteille, kannettaville tietokoneille ja muille USB-C-laitteille 60W USB-C Power Delivery -liitäntällä ja käytä samaa liitäntää varavirtalähteen lataamiseen 1,5 tunnissa. Venturen uudessa muotoilussa on suojaava kumihoikki, sisäänrakennettu 50 lumenin taskulamppu ja vedenpitävä pistoke, joka suojaaa liitäntöjä elementeiltä, kun niitä ei käytetä.



KYTKE MINUUN VIRTA

Venture 75 on suojatussa kuljetustilassa. Kytke se USB-liitäntään ennen käyttöä.

BRANCHEZ-MOI: Votre Venture 75 est en mode de transport. Branchez-le sur un port USB avant de l'utiliser.

これを差し込んで下さい Venture 75は保護モードで出荷されています。ご使用前にUSBポートに差し込んで下さい。

STECK MICH ZUERST EIN: Das Venture 75 wird im Schutzmodus geliefert. Vor dem ersten Gebrauch in einen USB-Port einstecken.

CONÉCTEME: El Venture 75 está en modo protector de envío. Conéctelo a un puerto USB antes de usarlo.

Akun merkivalot

- 1: 25 % lataus
- 2: 50 % lataus
- 3: 75 % lataus
- 4: 100 % lataus

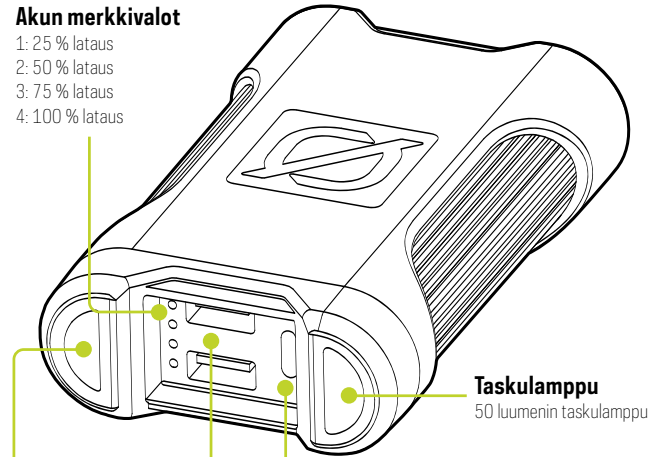

2x USB-A lähtöliitäntä

5V, jopa 3A (enint. 15W), säännelty

Taskulamppu PÄÄLLE/POIS | Merkivalo

Taskulamppu ja akun tason osoitin

Taskulamppu

50 lumenin taskulamppu

USB-C -tulo-/lähtöliitäntä

5-20V, jopa 3A (enint. 60W), säännelty

LATAA ENNEN KÄYTTÖÄ

Lataa Venture 75 oheisella USB-C-kaapelilla jännitteisestä USB-lähteestä. Käytä 45W USB-C-laturia (myydään erikseen) suurinopeuksiseen syötteen. Uusi Venture 75 toimitetaan suojaustilassa. Se estää itsestään purkautumisen, joka voi aiheutua pitkstä käyttämättömyydestä, kuten toimituksista.

Venture 75 ei lataa laitteitasi ennen kuin se on kytketty jännitteiseen USB-lähteeseen.

1. Kytke USB-C-kaapeli syötteen ja jännitteiseen USB-liitäntään.
2. Tiedät, että laite lataa, kun etuosassa olevat siniset merkkivalot syttyvät ja vilkkuvat. Kukin sininen merkkivalo edustaa 25 % akkukapasiteetista. Lataustila vilkkuu sinisen akun täyttyessä.
3. Venture 75 on täynnä ja käyttövalmis, kun kaikki valot palavat.
4. Venture 75 mahdollistaa samanaikaisen purkamisen ja latauksen, joten voit ladata laitteitasi ja Venture 75:tä samanaikaisesti.

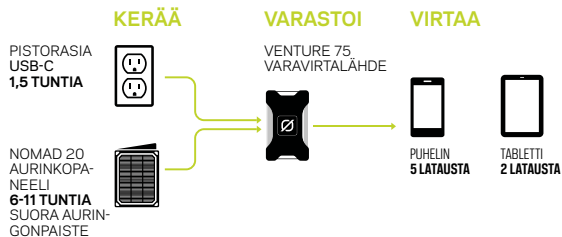

SOLAR READY™

Venture 75 on suunniteltu lataamaan nopeasti Goal Zero Nomad® -aurinkopaneeleista.

1. Kytke oheisen kaapelin USB-C-pää Venture 75 -laitteeseen ja USB-A-pää Nomad-paneelin takana olevaan USB-liitäntään.
2. Tiedät, että laite lataa, kun siniset merkkivalot syttyvät ja vilkkuvat. Kukin sininen merkkivalo edustaa 25 % akkukapasiteetista.
3. Venture 75 on täynnä ja käyttövalmis, kun kaikki valot palavat samaan aikaan.
4. Siniset merkkivalot vilkkuvat akun tason mukaan. Käytä sisäänrakennettua jalustaa suunnataksesi paneelin aurinkoa kohti aurinkopaneelista ladattaessa.



NOMAD 10
11-22 TUNTIA



NOMAD 20
6-11 TUNTIA



NOMAD 50
6 TUNTIA

LATAA LAITTEESI

Venture 75 on suunniteltu lataamaan puhelimia, tabletteja, POV-kameroita ja muita USB-ladattavia laitteita. Lataa jopa 3 laitetta samanaikaisesti.



OTSALAMPPU
JOPA 14
LATAUSTA



POV-KAMERA
14
LATAUSTA



PUHELIN
5
LATAUSTA



TABLETTI
2
LATAUSTA



KANNETTAVA
TIETOKONE
JOPA 1
UDELLEENLATAUS

TASKULAMPPU

Venture 75 -laitteessa on sisäänrakennettu 50 luumenin taskulamppu.

KÄYNNISTÄ/SAMMUTA

Käynnistä ja sammuta painamalla virta-akku/taskulamppu -painiketta 2 sekuntia.

JÄMÄKKÄ MUOTOILU

Venture 75:n IP67-luokitus antaa tehoa kaikkiin seikkailuihin, satoi tai paistoi. Kun vedenpitävä liitäntätulppa on kiinni, Venture 75 on suojattu pölyltä, hiekalta ja roskilta, ja voi kestää upotuksen veteen 1 metrin syvyyteen vähintään 30 minuutin ajaksi.

K: Miksi laitteeni ei lataudu?

V: Tarkista Venture 75 -laitteen akun taso painamalla akun merkkipainiketta. Käytä vain laitteen mukana toimitettuja, sertifioituja kaapeleita.

K: Onko Venture 75 täysin vedenkestävä?

V: Kyllä. Kun vedenpitävä luukku on kiinni, laitteen luokitus on IP67 ja se on suojattu pölyltä, hiekalta ja roskilta, ja voi kestää upotuksen veteen 1 metrin syvyyteen vähintään 30 minuutin ajaksi.

K: Miten taskulamppu toimii?

V: Venture 75 -laitteessa on sisäänrakennettu 50 luumenin taskulamppu, jota säädetään akun merkkipainikkeella. Sytytä ja sammuta taskulamppu painamalla painiketta 2 sekunnin ajan.

K: Mitä jos virta USB-C-laitteistani ei virtaa oikeaan suuntaan?

V: Venture 75 -laitteen USB-C-liitäntä on kahdensuuntainen. Eli virta voi kulkea sisään ja ulos. Jos virta ei kulje haluamaasi suuntaan, kokeile USB-C-kaapelin kytkemistä irti ja uudelleenkytkemistä muutaman kerran. Tämä virran suunta rekisteröidään uudelleen.

Venture 75 -varavirtalähde		LIITÄNNÄT:	
LATAUSAJAT:		USB-liitäntä (ulostulo)	5V, jopa 3A (enint. 15W), säännelty
GOAL ZERO Nomad 10	11-22 h	USB-C-portti (sisääntulo/ulostulo)	5-20V, jopa 3A (enint. 60W), säännelty
GOAL ZERO Nomad 20	6-11 tuntia	YLEISTÄ:	
GOAL ZERO Nomad 50	6 h	IP-luokitus	IP67
USB-C-lähde (60W)	1,5 h	Ketjutettavissa	Ei
AKKU:		Paino	577 g
Kennokemia	Li-ioni NMC	Mitat	15,6 x 9,6 x 2,9 cm
Kennotyyppi	18650 by LG chem	Käyttölämpötila	0-45 C
Kennon kapasiteetti	71,04 Wh (11,1V, 6400 mAh)	Sertifioinnit	
Yhden kennon kapasiteetti	19200mAh @ 3.7V	Takuu	12 kuukautta
Elinkaaret	Satoja sykliä		
Varastointikestävyys	Pidä kytkettynä, tai lataa joka 3-6 kuukausi		
Sulakkeet	Ei mitään		
Hallinnointijärjestelmä	Sisäänrakennettu lataus- ja matalan akkuvirran suojaus		

Muista **AKTIVOIDA TAKUU** osoitteessa goalzero.com/warranty

Snellaadtechnologie ontmoet robuuste duurzaamheid. De nieuwe Venture 75 combineert het beste van twee werelden. Onze verbeterde 19200 mAh powerbank heeft een IP67 stof-/waterdichtheidsclassificatie en een USB-C-poort die is ontworpen om het opladen te versnellen en het dragen van kabels te stroomlijnen. Start tablets, laptops en andere USB-C-apparaten op met de 60 W USB-C Power Delivery-poort en gebruik vervolgens dezelfde poort om de powerbank snel op te laden in 1,5 uur. Het frisse Venture-ontwerp heeft een beschermende rubberen hoes, een geïntegreerde zaklamp van 50 lumen en een waterdichte plug die uw poorten beschermt tegen de elementen wanneer deze niet in gebruik zijn.



SLUIT ME AAN

Venture 75 bevindt zich in beschermende verzendmodus.
Sluit hem voor gebruik aan op een USB-poort.

BRANCHEZ-MOI: Votre Venture 75 est en mode de transport. Branchez-le sur un port USB avant de l'utiliser.

これを差し込んで下さい Venture 75は保護モードで出荷されています。ご使用前にUSBポートに差し込んで下さい。

STECK MICH ZUERST EIN: Das Venture 75 wird im Schutzmodus geliefert. Vor dem ersten Gebrauch in einen USB-Port einstecken.

CONÉCTEME: El Venture 75 está en modo protector de envío. CONÉCTEME:

Batterijcontrole-lampjes

- 1: 25% opgeladen
- 2: 50% opgeladen
- 3: 75% opgeladen
- 4: 100% opgeladen

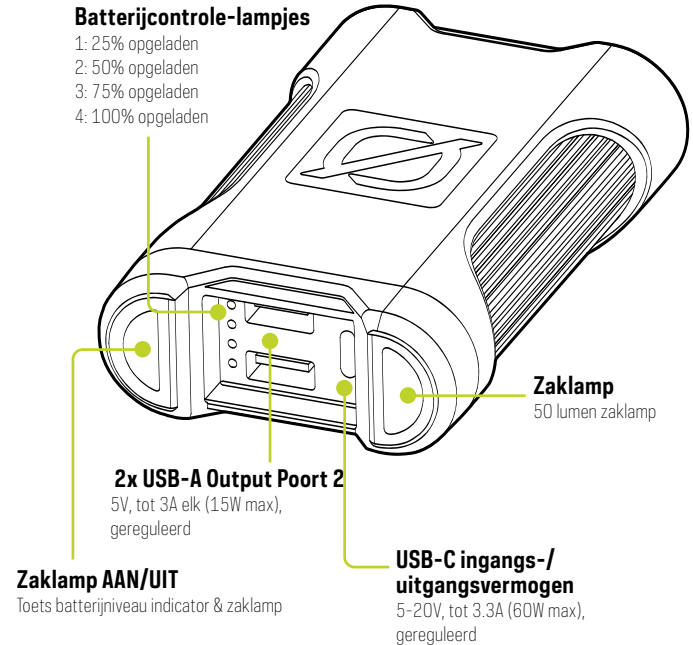

OPLADEN VOOR GEBRUIK ▲

Gebruik de meegeleverde USB-C-kabel om de Venture 75 op te laden vanaf een live USB-bron. Gebruik de 45 W USB-C-oplader (apart verkrijgbaar) voor een snelle invoer. Een nieuwe Venture 75 wordt geleverd in een beschermende modus om zelfontlading te voorkomen, mogelijk veroorzaakt door lange perioden van inactiviteit, zoals verzending.

De Venture 75 laadt je uitrusting pas op als deze is aangesloten op een live USB-bron.

1. Sluit de USB-C-kabel aan op de ingang en steek deze in een actieve USB-poort.
2. Je beseft dat hij aan het opladen is als de blauwe indicatielampjes aan de voorkant gaan branden en knipperen. Elk blauw indicatielampje staat voor 25% batterijcapaciteit. Naarmate de batterij vol raakt, knippert de laadstatus blauw.
3. Venture 75 is vol en klaar voor gebruik als alle lichtjes branden.
4. De Venture 75 maakt gelijktijdig ontladen en opladen mogelijk, zodat u uw uitrusting en Venture 75 tegelijkertijd kunt opladen.

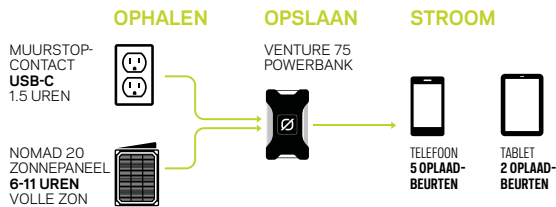

SOLAR READY™

Venture 75 is ontworpen om snel op te laden vanaf Goal Zero Nomad® Zonnepanelen.

1. Sluit het USB-C-uiteinde van de meegeleverde kabel aan op de Venture 75 en steek het USB-A-uiteinde in de USB-poort aan de achterkant van het Nomad-paneel.
2. Je beseft dat hij aan het opladen is als de blauwe indicatielampjes aan de voorkant gaan branden en knipperen. Elk blauw indicatielampje staat voor 25% batterijcapaciteit.
3. Venture 75 is vol en klaar voor gebruik als alle lichtjes branden.
4. Blauwe indicatielampjes knipperen afhankelijk van het batterijniveau. Gebruik bij het opladen via zonne-energie de ingebouwde standaard om uw paneel naar de zon te richten.



NOMAD 10
11-22 UREN



NOMAD 20
6-11 UREN



NOMAD 50
6 UREN

VOORZIE UW APPARAAT VAN STROOM

De Venture 75 is ontworpen om telefoons, tablets, POV-camera's en andere USB-apparaten op te laden. Laad tot 3 apparaten tegelijk op.



KOPLAMP
TOT 14
OPLAAD-
BEURTEN



POV CAMERA
14
OPLAAD-
BEURTEN



TELEFOON
5
OPLAAD-
BEURTEN



TABLET
2
OPLAAD-
BEURTEN



LAPTOP
TOT 1
OPLADEN

ZAKLAMP

De Venture 75 wordt geleverd met een ingebouwde zaklamp van 50 lumen.

AANZETTEN/UITZETTEN

Houd de Power Batt/Flashlight-knop 2 seconden ingedrukt om in en uit te schakelen.

ROBUUST ONTWERP

Dankzij de IP67-classificatie van de Venture 75 kun je elk avontuur aan, bij regen of zonschijn. Ja, als de waterproof deur volledig gesloten is wordt de unit beoordeeld op IP67 en is hij beschermd tegen stof, zand en vuil en is hij bestand tegen onderdompeling in water tot 75 meter voor ten minste 1 minuten.

V: Waarom laadt mijn apparatuur niet op?

A: Controleer het batterijniveau van de Venture Jump door de knop batterijstroom indicator in te drukken. Zorg dat u de gecertificeerde kabels die met uw apparatuur geleverd werden gebruikt.

V: Is de Venture 75 volledig waterproof?

A: Ja, als de waterproof deur volledig gesloten is wordt de unit beoordeeld op IP67 en is hij beschermd tegen stof, zand en vuil en is hij bestand tegen onderdompeling in water tot 1 meter voor ten minste 30 minuten.

V: Hoe werkt de zaklamp-functie?

A: De Venture Jump heeft een ingebouwde 75 lumen zaklamp die bediend wordt door de knop batterijstroom. Druk gewoon 2 seconden op de knop om de zaklamp aan en uit te zetten.

V: Wat moet ik doen als de stroom van mijn USB-C-apparaten niet op de juiste manier stroomt?

A: De USB-C-poort op de Venture 75 is bidirectioneel. Dit betekent dat de stroom in en uit kan stromen. Als de stroom niet naar wens verloopt, probeert u de USB-C-kabel een of twee keer los te koppelen en opnieuw aan te sluiten. Hierdoor wordt de richting waarin de stroom stroomt opnieuw geregistreerd.

Venture 75 Power Bank**LAADTIJDEN:**

Goal Zero Nomad 10	11-22 uur
Goal Zero Nomad 20	6-11 uur
Goal Zero Nomad 50	6 uur
USB-C bron	1.5 uur

ACCU:

Celchemie	Li-ion NMC
Celtype	18650 door LG chem
Celvermogen	71.04Wh (11.1V, 6400mAh)
Enkel Cel vermogen	19200mAh @ 3.7V

Levenscyclussen Honderden cyclussen

Houdbaarheid Ingeplugd houden of elke 3 tot 6 maanden opladen







Zekeringen Geen

Managementsysteem Ingebouwde bescherming laden en batterij bijna leeg

POORTEN:

USB-poort (output)	5V, tot 3A elk (15W max), gereguleerd
USB-C poort (uitvoer)	5-20V, tot 3.3A (60W max), gereguleerd

ALGEMEEN:

IP Beoordeling	IP67
Te koppelen	Nee
Gewicht	1.27 lbs (577 gr)
Afmetingen	6.1 x 3.8 x 1.1 in (15.6 x 9.6 x 2.9 cm)
Gebruikstemperatuur	32-113F (0-45C)
Certificaten	      

Snabbladdningsteknik möter robust hållbarhet. Nya Venture 75 har det bästa av två världar. Vår uppgraderade powerbank på 19 200 mAh har en dammtät/vattentätt IP67-klassning och en USB-C-port utformad för att påskynda laddning och effektivisera kabelbärande. Ladda surfplattor, bärbara datorer och andra USB-C-enheter med 60 W USB-C Power Delivery-porten och använd sedan samma port för att snabbt ladda powerbanken på 1,5 timmar. Den fräscha Venture-designen har en skyddande gummiomslutning, integrerad ficklampa med 50 lumen och en vattentät kontakt som skyddar dina portar mot elementen när de inte används.



ANSLUT MIG

Venture 75 är i skyddad fraktläge.
Anslut den till en USB-port innan användning.

BRANCHEZ-MOI: Votre Venture 75 est en mode de transport. Branchez-le sur un port USB avant de l'utiliser.

これを差し込んで下さい Venture 75は保護モードで出荷されています。ご使用前にUSBポートに差し込んで下さい。

STECK MICH ZUERST EIN: Das Venture 75 wird im Schutzmodus geliefert. Vor dem ersten Gebrauch in einen USB-Port einstecken.

CONÉCTEME: El Venture 75 está en modo protector de envío. Conéctelo a un puerto USB antes de usarlo.

Batteriindikatorljus

- 1: 25% laddad
- 2: 50% laddad
- 3: 75% laddad
- 4: 100% laddad

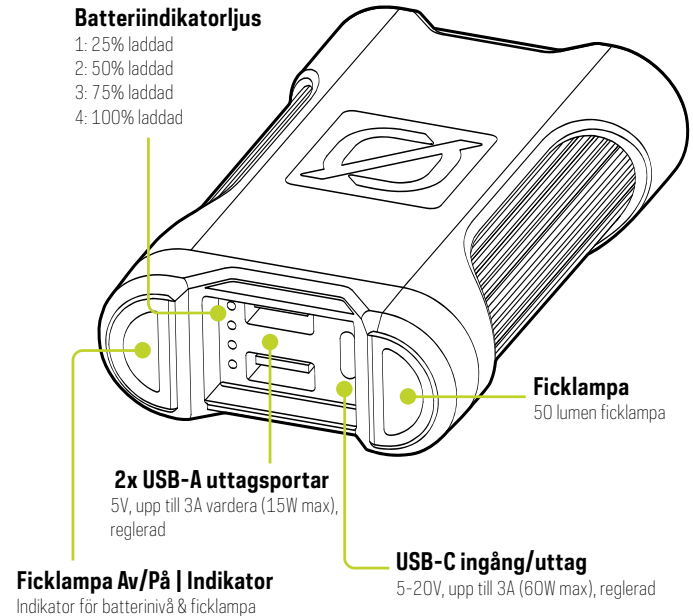

LADDA INNAN ANVÄNDNING ⚠

Använd den medföljande USB-C-kabeln för att ladda Venture 75 från en aktiv USB-källa. Använd USB-C-laddaren på 45 W (säljs separat) för en höghastighetsingång. En ny Venture 75 levereras i skyddsläge för att förhindra självurladdning, potentiellt orsakad av långa perioder av inaktivitet, som frakt.

Venture 75 laddar inte din utrustning förrän den är ansluten till en aktiv USB-källa.

1. Anslut USB-C-kabeln till ingången och anslut den till en USB-port.
2. Du vet att den laddas när blå indikatorlampor tänds på framsidan och blinkar. Varje blå indikatorlampa representerar 25% batterikapacitet. När batteriet laddas blinkar laddningstillståndet blått.
3. Venture 75 är fullt och redo när alla lampor är tända.
4. Venture 75 möjliggör urladdning och laddning samtidigt så att du kan ladda din utrustning och Venture 75 samtidigt.

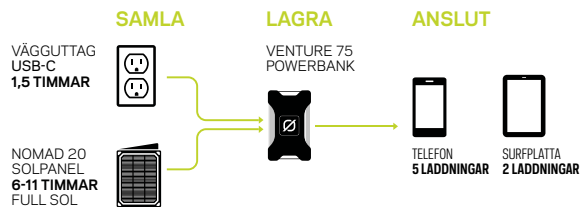

SOLAR READY™

Venture 75 är utformad för att laddas snabbt från Goal Zero Nomad® solpaneler.

1. Anslut USB-C-ändan av den medföljande kabeln till Venture 75 och anslut USB-A-ändan till USB-porten på baksidan av Nomad-panelen.
2. Du vet att den laddas när de blå indikatorlamporna tänds och blinkar. Varje blå indikatorlampa representerar 25% batterikapacitet.
3. Venture 75 är fullt och redo när alla lampor är tända.
4. De blå indikatorlamporna blinkar enligt batterinivå. När du laddar från solenergi, använd det inbyggda stödet för att vinkla din panel mot solen.



NOMAD 10
11-22 TIMMAR



NOMAD 20
6-11 TIMMAR



NOMAD 50
6 TIMMAR

LADDA DIN UTRUSTNING

Venture 75 är utformad för att ladda telefoner, surfplattor, POV-kameror och andra USB-drivna enheter. Ladda upp till 3 enheter samtidigt.



PANNLAMP
UPP TILL 14
LADDNINGAR



POV-KAMERA
14
LADDNINGAR



TELEFON
5
LADDNINGAR



SURFPLATTA
2
LADDNINGAR



BÄRBAR DATOR
UPP TILL 1
LADDNING

FICKLAMP

Venture 75 har en inbyggd 50 lumen ficklampa.

PÅ/AV

Tryck på knappen för batteri/ficklampa i 2 sekunder för att slå på och stänga av.

ROBUST DESIGN

Venture 75:s IP67-klassning gör att du har ström under alla äventyr, oavsett om det är regn eller solsken. När det vattentäta locket är helt stängt är Venture 75 skyddad mot damm, sand och skräp och tål nedsänkning upp till 1 meter i vatten under minst 30 minuter.

F: Varför laddas inte min utrustning?

S: Kontrollera batterinivån på Venture 75 genom att trycka på batteriindikatorknappen.

Se till att använda de certifierade kablarna som följde med din utrustning.

F: Är Venture 75 helt vattensäker?

S: Ja, med den vattentäta luckan helt stängd är enheten klassad enligt IP67 och är skyddad mot damm, sand och skräp och tål nedsänkning upp till 1 meter i vatten i minst 30 minuter.











F: Hur fungerar ficklampan?

S: Venture 75 har en inbyggd ficklampa på 75 lumen som styrs av batteriindikatorknappen.

Tryck och håll ned knappen i 2 sekunder för att sätta igång och stänga av ficklampan.

F: Vad händer om strömmen från mina USB-C-enheter inte flödar på rätt sätt?

S: USB-C-porten på Venture 75 är dubbelriktad. Vilket innebär att ström kan flöda in och ut. Om strömmen inte flödar som du vill kan du försöka koppla bort och ansluta USB-C-kabeln igen en eller två gånger. Detta kommer att återregistrera i vilken riktning strömmen flödar.

Venture 75 Power Bank		PORTAR:	
LADDTIDER:		USB-port (uttag)	5V, upp till 3A vardera (15W max), reglerad
GOAL ZERO Nomad 10	11-22 timmar	USB-C-port (ingång/uttag)	5-20V, upp till 3A (60W max), reglerad
GOAL ZERO Nomad 20	6-11 timmar	ALLMÄNT:	
GOAL ZERO Nomad 50	6 timmar	IP-klassning	IP67
USB-C-källa (60W)	1,5 timmar	Kedjekopplingsbar	Nej
BATTERI:		Vikt	577 g (1,27 lbs)
Cellkemi	Li-ion NMC	Mått	15,6 x 9,6 x 2,9 cm (6,1 x 3,8 x 1,1 tum)
Celltyp	18650 från LG chem	Drifttemperatur	32-113F (0-45C)
Cellkapacitet	71,04Wh (11,1V, 6400mAh)	Certifieringar	         

GOAL ZERO HEADQUARTERS

675 West 14600 South

Bluffdale, UT 84065

Designed in the U.S.A.

Made in China

1-888-794-6250

Goal Zero Switch and Nomad are trademarks of Goal Zero LLC.

This equipment has been tested and found to comply with the limits for a Class B digital device, pursuant to part 15 of the FCC Rules. These limits are designed to provide reasonable protection against harmful interference in a residential installation. This equipment generates, uses and can radiate radio frequency energy and, if not installed and used in accordance with the instructions, may cause harmful interference to radio communications. However, there is no guarantee that interference will not occur in a particular installation. If this equipment does cause harmful interference to radio or television reception, which can be determined by turning the equipment off and on, the user is encouraged to try to correct the interference by one or more of the following measures:

- Reorient or relocate the receiving antenna.
- Increase the separation between the equipment and receiver.
- Connect the equipment into an outlet on a circuit different from that to which the receiver is connected.
- Consult the dealer or an experienced radio/TV technician for help.

This device complies with part 15 of the FCC Rules. Operation is subject to the following two conditions: (1) This device may not cause harmful interference, and (2) this device must accept any interference received, including interference that may cause undesired operation.

GOALZERO.COM